



PQ12 Actual Size

Benefits

- Compact miniature size
- Precise position feedback
- Limit switches
- Simple control
- Low voltage
- Equal push/pull force
- Easy mounting

Applications

- Robotics
- Consumer appliances
- Toys
- RC vehicles
- Automotive
- Industrial Automation



Miniature Linear Motion Series · **PQ12**

Firgelli Technologies' unique line of Miniature Linear Actuators enables a new generation of motion-enabled product designs, with capabilities that have never before been combined in a device of this size. These tiny linear actuators are a superior alternative to designing your own push/pull mechanisms.

The PQ12 actuators are complete, self contained linear motion devices with position feedback for sophisticated position control capabilities, or end of stroke limit switches for simple two position automation. Driving them couldn't be easier, simply apply a DC voltage to extend the actuator, and reverse the polarity to retract it. Several gear ratio's and voltage options are available to give you varied speed/force configurations.

PQ12 Specifications

<u>Gearing Option</u>	<u>30:1</u>	<u>63:1</u>	<u>100:1</u>
Peak Power Point	7N @ 12mm/s	20N @ 7mm/s	27N @ 4mm/s
Peak Efficiency Point	4N @ 18mm/s	10N @ 9mm/s	14N @ 7mm/s
Max Speed (no load)	25mm/s	12mm/s	9mm/s
Max Force (lifted)	9N	24N	35N
Max Side Load	5N	10N	15N
Back Drive Force	15N	35N	60N
Stroke	20 mm		
Input Voltage	6 or 12 VDC		
Stall Current	550mA @ 6V, 220mA @ 12V		
Mass	15g		
Operating Temperature	-10°C to +50°C		
Positional Accuracy	±0.1mm		
Lifetime	20,000 strokes, 20% Duty Cycle		
Audible Noise	55dB @ 45cm		
Ingress Protection	IP-54		
Feedback Potentiometer	1/8W Non-Buffered 10kΩ Potentiometer		
Limit Switches	Max. Current Leakage: 8uA		

Basis of Operation

The PQ12 is designed to push or pull a load along its full stroke length. The speed of travel is determined by the load applied. (See the Load Curves). When power is removed the actuator will hold its position, unless the applied load exceeds the backdrive force. Stalling the actuator for short periods will not cause damage, however repeated stalling will shorten the life of the actuator.

Ordering

Small quantity orders can be placed directly online at www.firgelli.com. Each actuator ships with two mounting brackets, M3 mounting hardware, and one FPC ribbon cable connector. To extend the length of the ribbon cable, solder holes are provided to attach a section of wire cable of your choice.



Firgelli Technologies Inc.

1550 Mileva Lane
Victoria, BC V8N 2V5
Canada

1 (206) 347-9684 phone
1 (888) 225-9198 toll-free
1 (206) 347-9684 fax

sales@firgelli.com
www.firgelli.com

PQ12 Specifications

Load Curves

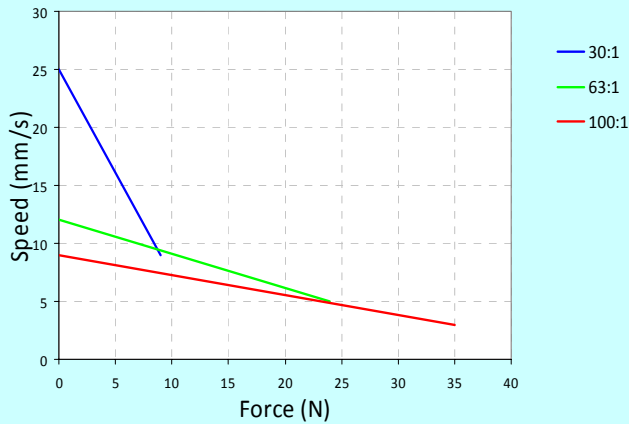

Current Curves

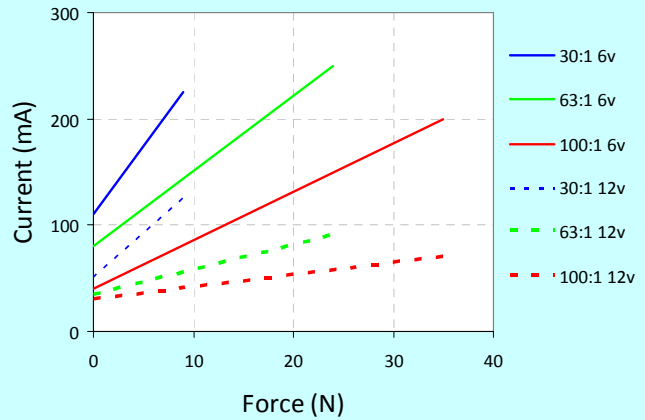

Model Selection

The PQ12 has 3 configuration choices: Gear Ratio, Voltage and Controller. PQ12 options are identified according to the following scheme:

PQ12-GG-VV-C

feature	options
GG: Gear reduction ratio (refer to load curves above)	30, 63, 100 (lower ratios are faster but push less force, and vice versa)
VV: Voltage (DC volts)	6, 12
C: Controller	P Potentiometer Feedback S Limit Switches

PQ12 Controller Options

Option S – End of Stroke Limit Switches

WIRING: (see next page for pin numbering)

- 1- Limit Switch Detection (Optional)
- 2- Actuator Motor Power
- 3- Actuator Motor Power
- 4- Not Connected
- 5- Not Connected

The –S actuators have limit switches that will turn off power to the motor when the actuator reaches within 1mm of the end of stroke. Internal diodes allow the actuator to reverse away from the limit switch. The limit switches cannot be moved. While voltage is applied to the motor power pins (2 & 3) the actuator extends. Reverse the polarity and the actuator retracts. This can be accomplished manually with a DPDT switch or relay, or using an H-Bridge circuit. The –S model cannot be used with the CIB control board. Pin #1 can be used to sense when the actuator has reached the end limits. See our FAQ page for a simple schematic to light an LED when the limits are reached.

Option P – Potentiometer Position Feedback

WIRING: (see next page for pin numbering)

- 1 – Feedback Potentiometer negative reference rail
- 2 – Actuator Motor Power
- 3 – Actuator Motor Power
- 4 – Feedback Potentiometer positive reference rail
- 5 – Feedback Potentiometer wiper

The –P actuators have no built in controller, but do provide an analog position feedback signal that can be input to an external controller. While voltage is applied to the motor power pins (2 & 3) the actuator extends. Reverse the polarity and the actuator retracts. This can be accomplished manually with a DPDT switch or relay, or using an H-Bridge circuit. Position of the actuator stroke can be monitored by providing any stable low and high reference voltage on pins 1 & 4, then reading the position signal on pin 5. The voltage on pin 5 will vary linearly between the two reference voltages in proportion to the position of the actuator stroke.

The PQ12 –P actuators can be used as a linear servo by connecting the actuator to a microcontroller such as the CIB control board offered by Firgelli. This control board reads the position signal from the PQ12, compares it with your input control signal then commands the actuator to move via an on-board H-bridge circuit. The CIB allows any one of the following control inputs: Analog 0-5V or 4-20mA, or Digital 0-5V PWM or 1-2ms Standard RC. The RC input effectively transforms your PQ12 into a linear servo which is a direct replacement for any common hobby servo used in RC toys and robotics. Refer to the CIB datasheet for more details.

Special Notes:

The PQ12 model numbering scheme has changed as of 1st Jan 2010. The old model numbers PQ-12s and PQ-12f have been replaced by PQ12-30-6-P and PQ12-63-6-P respectively.



Firgelli Technologies Inc.

1550 Mileva Lane
Victoria, BC V8N 2V5
Canada

1 (206) 347-9684 phone
1 (888) 225-9198 toll-free
1 (206) 347-9684 fax

sales@firgelli.com
www.firgelli.com

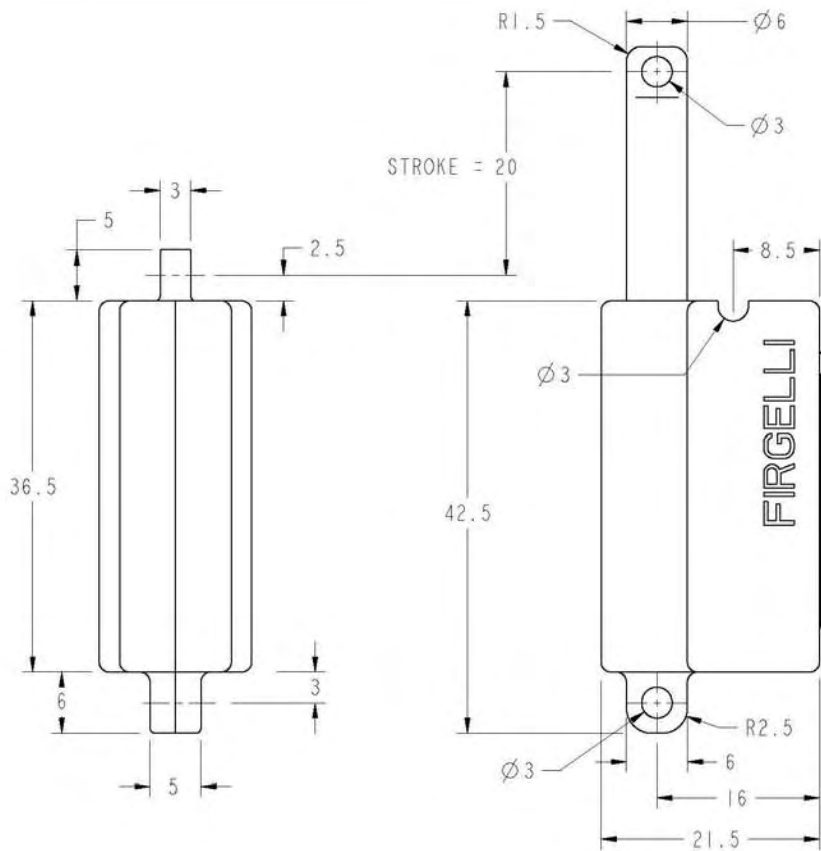

MOUNTING BRACKET
HOLES FOR M3 MACHINE SCREWS

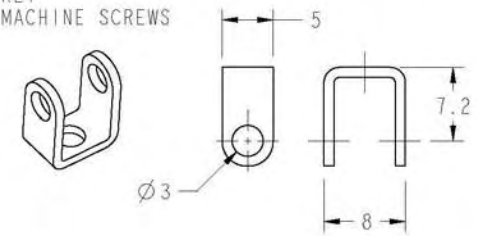

WIRING (PIN CONNECTIONS):

PQ12 -P OPTION
 PIN 1 - POTENTIOMETER REFERENCE
 PIN 2 - ACTUATOR POWER
 PIN 3 - ACTUATOR POWER
 PIN 4 - POTENTIOMETER REFERENCE
 PIN 5 - POTENTIOMETER WIPER

PQ12 -S OPTION
 PIN 1 - LIMIT DETECTION (OPTIONAL)
 PIN 2 - ACTUATOR POWER
 PIN 3 - ACTUATOR POWER
 PIN 4 - NOT CONNECTED
 PIN 5 - NOT CONNECTED

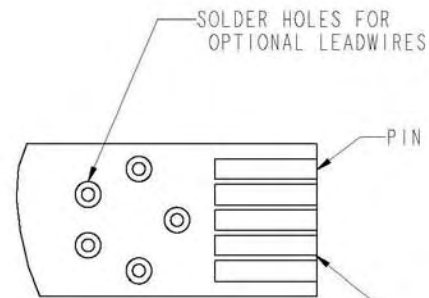

DETAIL A
SCALE 5:1

1 MM PITCH 5 POS FPC/FFC TERMINALS
MATING CONNECTOR:
FCI #HLW5S-2C7LF

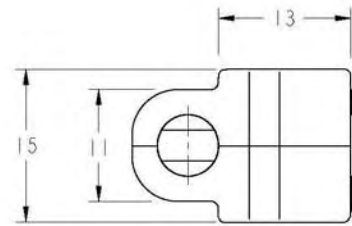
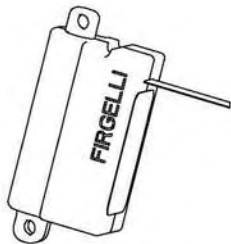

FLEX_PCB
LENGTH=120mm

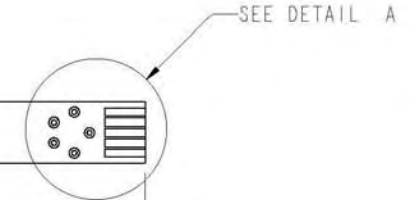

ALL DIMENSIONS IN MILLIMETERS

PQ12 ACTUATOR
DIMENSIONS



Copyright 2010 © Firgelli Technologies Inc.



Firgelli Technologies Inc.

1550 Mileva Lane
 Victoria, BC V8N 2V5
 Canada

1 (206) 347-9684 phone
 1 (888) 225-9198 toll-free
 1 (206) 347-9684 fax

sales@firgelli.com
 www.firgelli.com